

# 5/24 FRESE REGOLABILI PER CANALI DA 8 A 35

GROOVING CUTTER HEADS ADJUSTABLE FROM 8 TO 35 mm



FRESE REGOLABILI PER INCASTRI DA 8 A 35 mm  
CON COLTELLI REVERSIBILI .  
ANELLI COMPRESI.

GROOVING CUTTER HEADS WITH REVERSIBLE HW KNIVES.  
TO MAKE GROOVES FROM 8 TO 35 mm.  
SPACERS RINGS INCLUDED.

5/24

**MAN** **MEC**

Codice nr. HW	D. mm.	B mm.	d. mm.	Z+V	T
5/24 08	140	8-23	30-35	6+4	35
5/24 12	140	12.5-35	30-35	6+4	45
5/24 30	180	8-30	30-35	6+4	55

FORI A RICHIESTA/BORES AVAILABLE mm 31.75-40-50

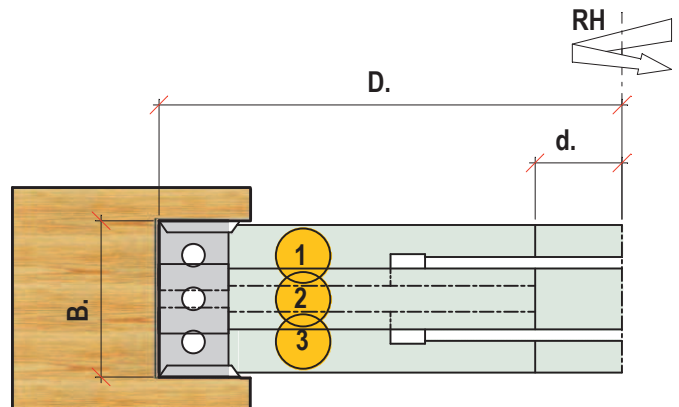

15S24	ANELLI PER IRINGS SET FOR	8-24 mm
15S30	ANELLI PER IRINGS SET FOR	8-30 mm
15S35	ANELLI PER IRINGS SET FOR	12-35 mm

## Ricambi/Spare parts

Codice nr.	Dimensioni		
000/180	14x14x2		
000/016	M5x6		VITE/SCREW B=8 mm
000/018	M5x8		
000/039A	T25		
000/181	7.5x12x1.5		
000/183	12x12x1.5		
000/184	15x12x1.5		
000/160	C7		
000/151	C10		
000/152	C14		
000/009A	M5x15		
000/008	M8x15		
000/031	2.5 mm		
000/032	4 mm		
000/044	0.4-0.8-1 mm		CALIBRO/GAUGE

# 5/26 GRUPPI PER PERLINE E PARQUET

## TONGUE AND GROOVE CUTTERSET

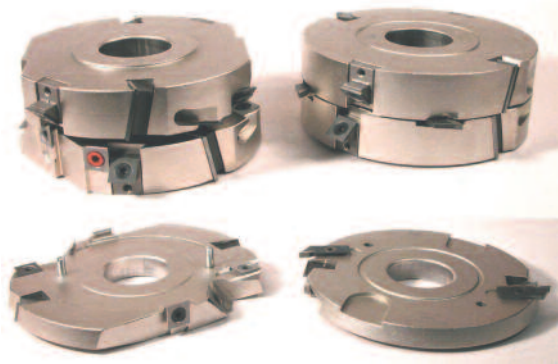

GRUPPI DI 4 o 6 TESTE PER 4 TIPI DI PERLINE.  
DA USARE SU SCORNICIATRICE. TUTTI I PROFILI  
POSSONO AVERE ARIA DI 0.5mm INSERENDO  
UN COLTELLINO SUL DIAMETRO MAX.  
INCLUSI ANELLI PER SPESSORE MINIMO.

SET WITH 4 OR 6 HEADS TO MAKE 4 DIFFERENT  
PROFILES OF TONGUE AND GROOVE.  
RINGS FOR MINIMUM CUTTING DEPTH.

5/26

TABELLA DEI GRUPPI

MEC

Codice nr. HW	PROFILO PROFILE	GRUPPO COMPOSTO DA SET OF TOOLS	H LEGNO WOOD
5/26A	A	1+2 3+4	10-40
5/26B	B	1+2 3+4	12-40
5/26C	C	1+2 3+4	14-40
5/26D	D	1+5 3+6	10-30

n max 8000

fresa tool	D. mm.	B mm.	d. mm.	Z+V+Sp
1	155	30	40	2+4+2
2	155	30	40	2+4+2
3	140	30	40	2+4+2
4	140	30	40	2+4+2
5	155	15	40	2+4+2
6	160	20	40	2+4+2

SERIE COMPLETA/WHOLE TOOL SET

5/26 SC A+B+C+D 1+2+3+4+5+6 10-40

A RICHIESTA/ONLY ON REQUEST

5/26 N SERIE ANELLI PER SPESSORE MAX  
RINGS SET FOR MAXIMUM REGULATION

Ricambi/Spare parts

Codice nr. Dimensioni

000/180

14x14x2



000/G3.5D  
000/G3.5S

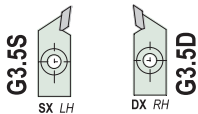

000/018

M5x8



000/039A

T25



000/183

12x12x1.5



000/186

30x12x1.5

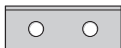

000/165

C26



000/151

C10

000/008

M8x15



000/031

2.5 mm



000/032

4 mm

000/044

0.4-0.8-1 mm CALIBRO/GAUGE

000/203

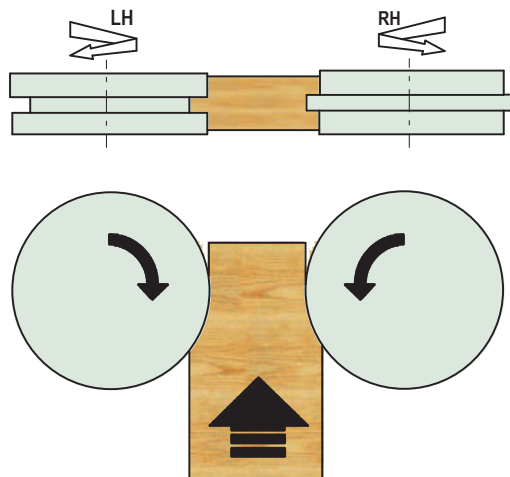
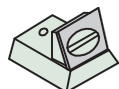

# APPLICAZIONI GRUPPI 5/26

## APPLICATIONS WITH CUTTERSET 5/26

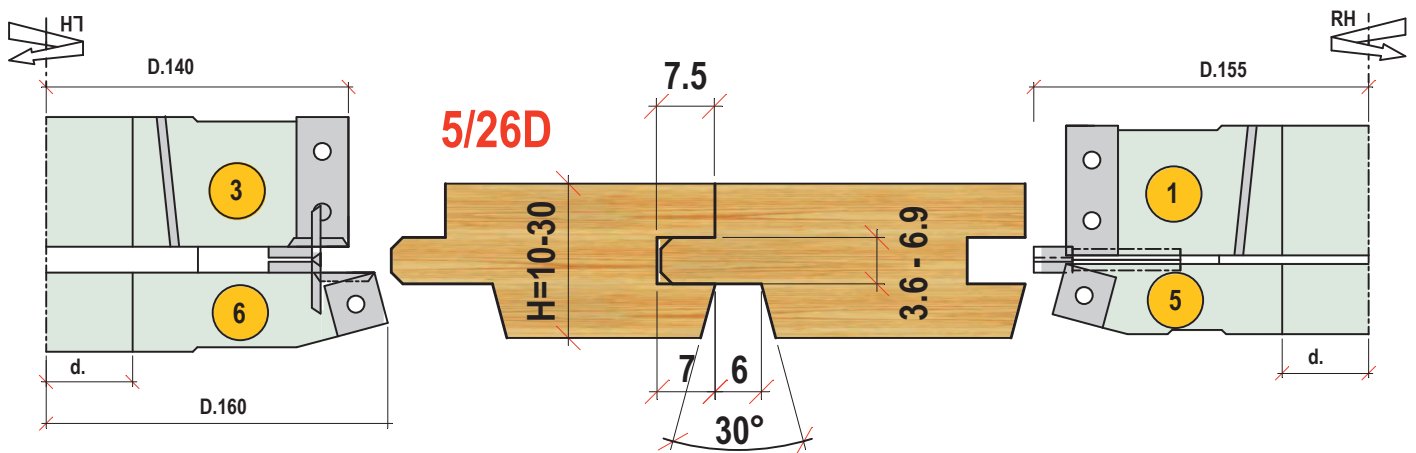
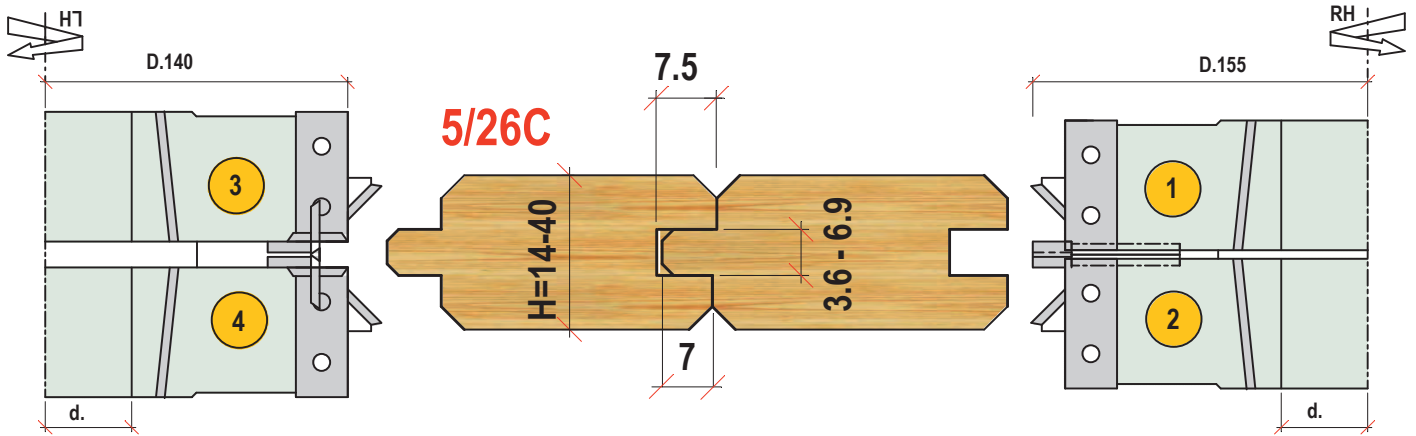
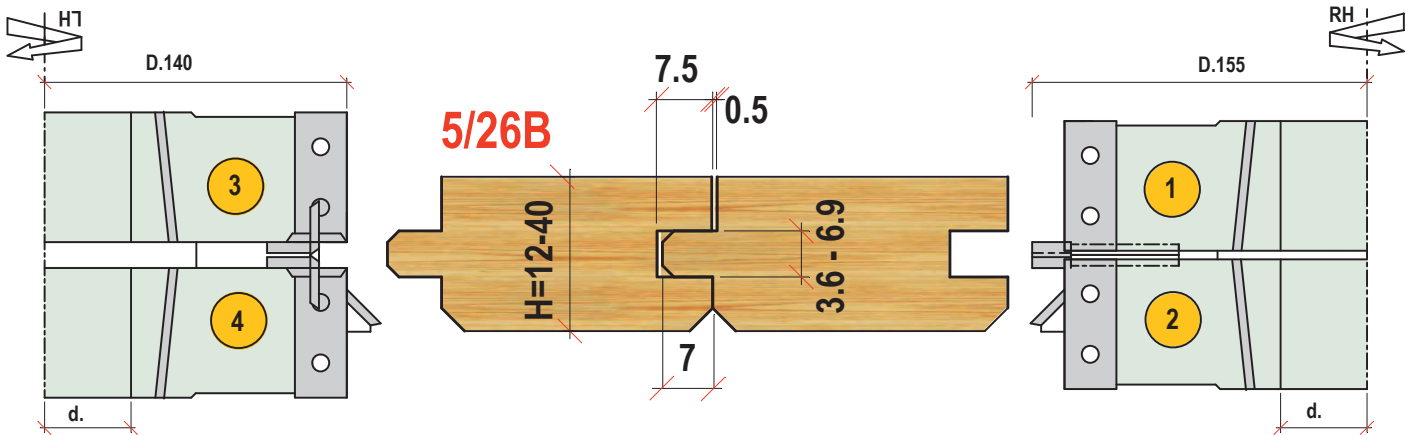
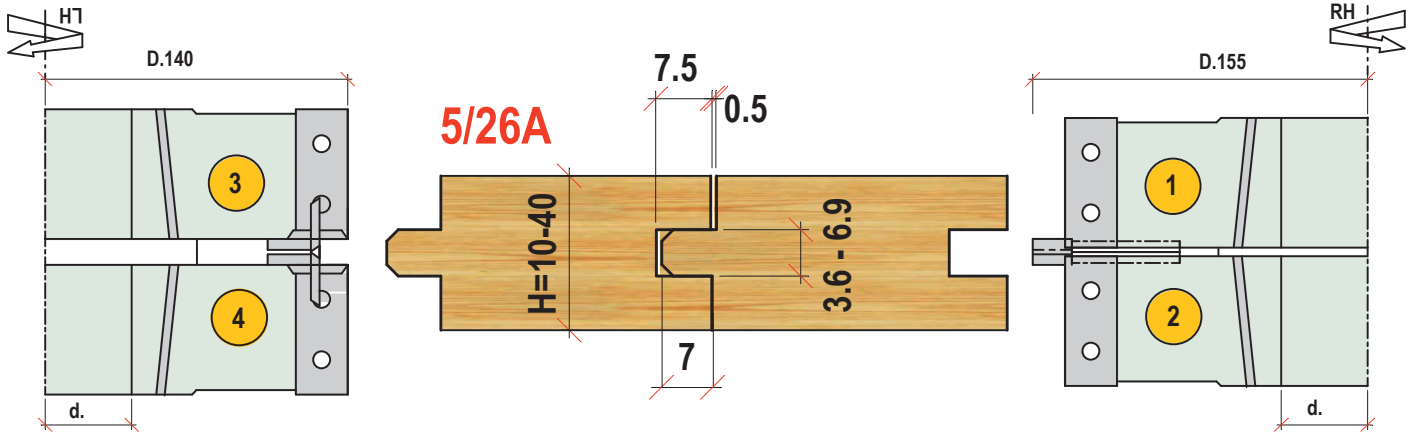

# 5/27 GRUPPO PER RAGGI E SMUSSI

## CHAMFERING AND ROUNDING SET



5/27

n max 8000

**MEC**

Codice nr. HW	R mm	fresa tool	D. mm.	B mm.	d. mm.	Z
5/27 01	2-6	1	135	16	30-35	3
5/27 02		2	125	50	30-35	3
5/27 03	2-6	3	135	16	30-35	3

5/27 GRUPPO COMPLETO-SET OF TOOLS 1+2+3

FORI A RICHIESTA/BORES AVAILABLE mm 31.75-40-50

**NELL'ORDINE INDICARE IL TIPO DI PROFILO**  
SPECIFY THE PROFILE ON THE ORDER

**ANELLI NON COMPRESI**  
SPACER RINGS ON REQUEST

TO SPECIFY THE PROFILE ON THE ORDER

### Ricambi/Spare parts

Codice nr. Dimensioni

27P45	45° 16x17.5x2	
27P2	R2 16x17.5x2	
27P3	R3 16x17.5x2	
27P4	R4 16x17.5x2	
27P5	R5 16x17.5x2	
27P6	R6 16x17.5x2	
000/187	50x12x1.5	

C27 14 mm  
000/155 C48

000/008 M8x15

000/032 4 mm

000/025 VITE M5 PER RIFERIMENTO

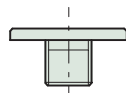

GRUPPO DI 3 FRESE PER RAGGIARE E SMUSSARE. COLTELLI IN HW CON DOPPIO PROFILO. R2-3-4-5-6 e 45°.

ANELLI NON COMPRESI.

SET FORNITO CON UN SOLO PROFILO

SET OF THREE ADJUSTABLE CUTTER HEADS WITH SPACER RINGS (NOT SUPPLIED).

PROFILED HW KNIVES R2-3-4-5-6 AND 45°.

SET SUPPLIED WITH ONE PROFILE ONLY

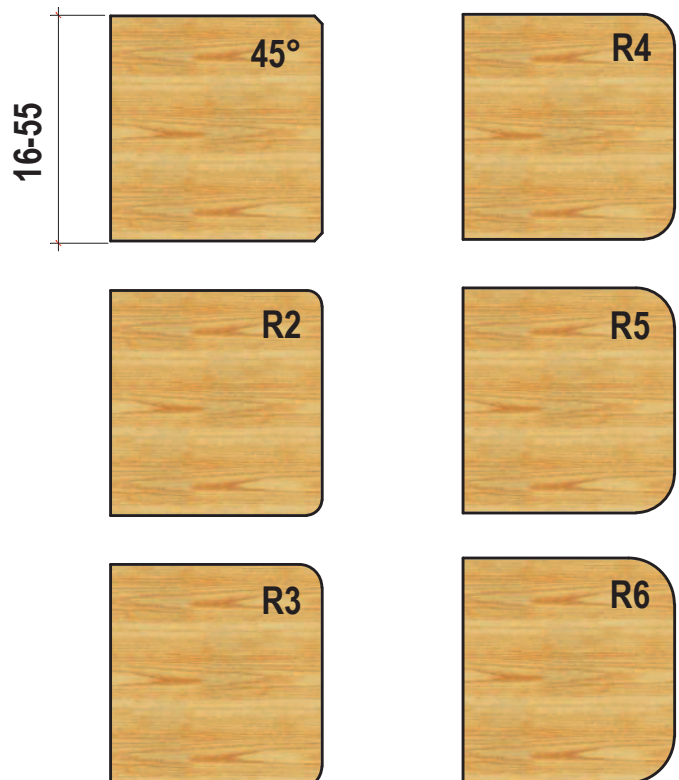
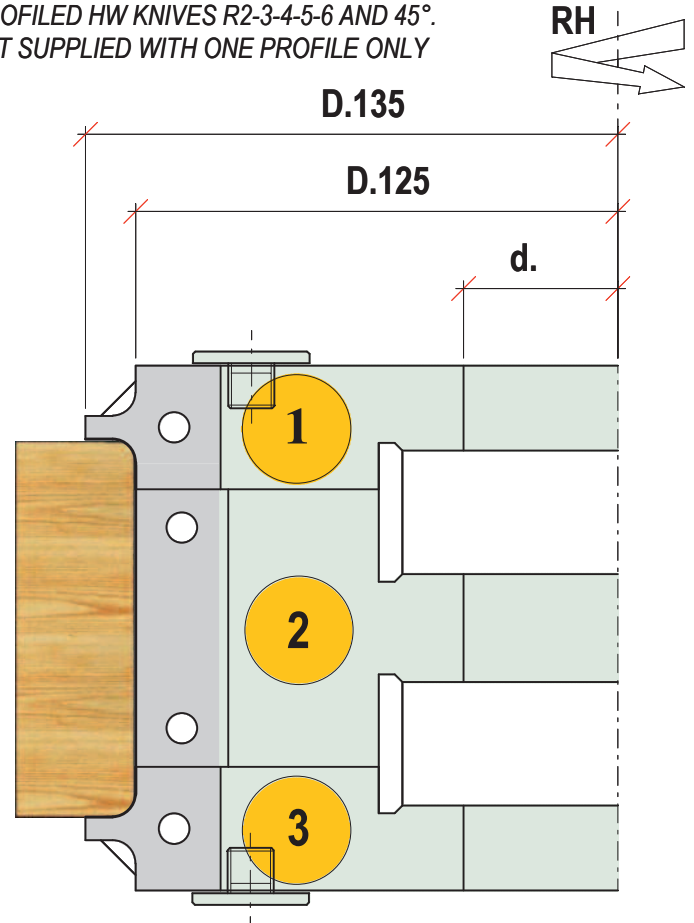

# 5/R4 FRESE REGOLABILI DA 4-7.5 / 16 mm

ADJUSTABLE GROOVING CUTTER HEADS FROM 4 TO 7.5 OR 16 mm



FRESE REGOLABILI PER INCASTRI SOTTILI DA 4-7.5 mm  
E DA 4-16 mm CON COLTELLI HW REVERSIBILI.  
ANELLI COMPRESI.

GROOVING CUTTER HEADS WITH REVERSIBLE HW KNIVES.  
WITH 2 OR 3 ADJUSTABLE PARTS FROM 4 TO 7.5 mm OR  
4 TO 16 mm.

**5/R4**

D.150 n max 7600  
D.180 n max 6500

**MAN**

**MEC**

Codice nr. HW	D. mm.	B mm.	d. mm.	Z+V	T mm.
5/R 1504	150	4 - 7.5	30-35	8+4	30
5/R 1516	150	4-16	30-35	8+4+2	30
5/R 1804	180	4 - 7.5	30-35	8+4	37
5/R 1816	180	4-16	30-35	8+4+2	37
5/R 1508	150	8	30-35	2	
5/R 1808	180	8	30-35	2	

FORI A RICHIESTA/BORES AVAILABLE mm 31.75-40-50

15S04 SERIE ANELLI x 4 mm-RINGS SET FOR 4 mm  
15S16 SERIE ANELLI x 16 mm-RINGS SET FOR 16 mm

Ricambi/Spare parts

Codice nr.	Dimensioni	
000/190	14x14x1.2	
000/002	∅ 9.9 mm	DADO PER RASANTE NUT FOR SPUR
000/196	18x18x1.95	
000/003	∅ 12 mm	
000/001	M4x0.5x3.2	
000/037	T9	
000/181	7.5x12x1.5	
000/160	C7	
000/009A	M5x15	
000/031	2.5 mm	

